



# NEW HOLLAND

## W130<sub>B</sub> W130<sub>BTC</sub>



	W130B	W130BTC
MAXIMUM POWER	128 kW - 172 hp	
MAX OPERATING WEIGHT	12 940 kg	13 055 kg
BUCKET CAPACITY	2.0 - 2.4 m <sup>3</sup>	2.0 - 2.1 m <sup>3</sup>



**NEW HOLLAND**

**CONSTRUCTION**

**BUILT AROUND YOU**

# W130B

THE NEW

## T NEW CNH TIER 3A ENGINE

The new turbo, aftercooled, electronically controlled CNH engine mounted on W130B is a jewel of technology which utilises the direct injection **Common Rail** and **EGR** systems to drastically reduce fuel consumption, noise and pollution. It features **4 valves** per cylinder, higher maximum power **128 kW** at lower r.p.m., increased maximum torque respect the previous model and an electronically controlled **Multiple Work Modes**.

## T HYDRAULIC SYSTEM

The **Load Sensing, Closed Centre** hydraulic system, delivers its power when and where it is needed. It also allows simultaneous movements independently from power required and engine r.p.m. Steering effectiveness and safety are assured by a **demand valve** which prioritises the diversion of necessary flow from the pump to the **emergency steering** gear pump, which is independent and automatic. A high efficiency system that contributes towards improved fuel economy, reduced heat generation and which **optimizes cycles and production**.

## F AXLES

- Front and rear axles feature:
- **Standard Limited Slip differential**
  - **HD outboard planetary reduction final drives**
  - **Maintenance-free outboard wet disc brakes**
  - **Rear axle oscillation up to 24°**

All that means improved traction on slippery ground conditions, extended tyre life thanks to reduced spin, reduced axles shaft stress by developing torque at the wheels and enhanced confidence when working on rough and uneven ground **for higher safety, durability and reduced operating costs**.



# LOOK OF PERFORMANCE

## EXCLUSIVE COOLING SYSTEM

**T**he New Holland advanced and **exclusive Cooling Module**, is a cube positioned in the centre of the machine with all radiators mounted around three of its sides and the hydraulic tank positioned in the centre, to optimise both space and cooling effect. A hydraulically driven fan, automatically actuated by a thermostatic sensor, draws fresh and clean air from outside through the radiators and the tank and blows it over the engine to the rear of the machine. The fan is reversible to easily clean the radiators. The tank position, high on the pump, eliminates risk of cavitation. An exclusive feature that **enhances component efficiency and durability.**

## A NEW SPACE LAB CAB

- A modern, safe and comfortable cab featuring:
- Bucket corners, wheels and 360° outstanding visibility
  - Easy entrance thanks to a 580 mm wide door and a stair with larger anti-slip steps
    - Internal volume increased by 13%
  - integrated ROPS and FOPS structure and tinted safety glass
    - Standard pressurization and optional climatization
    - Fingertip loader control

A cab designed to grant maximum operator comfort and safety for **increased production and profitability.**



# W130B THE POWER

## NEW TIER 3A COMMON RAIL ENGINE



This new CNH Common Rail engine is a jewel of technology, designed to reduce fuel consumption and pollution.

It features higher maximum power **128 kW** at lower crankshaft revolution 1800 r.p.m. (versus 2000 r.p.m. of the previous model), increased maximum torque of **73 daNm** and electronically controlled **Multiple Work Modes**.

The **Common Rail** system assures the injection of fuel in the cylinders at very high pressure, optimising nebulisation and mix with an increased quantity of turbocharged and after-cooled air, thus delivering a perfect and total fuel combustion.

In addition, the **EEMS** (Engine Electronic Management System) controls the “right moment” to introduce the “right quantity” of fuel in the cylinders.

These features provide **higher engine efficiency and lower fuel consumption** and, thanks to the **EGR (Exhaust Gas Recirculation)**, part of the exhaust gas is reintroduced in the cylinders, reducing the combustion temperature and contributing to **reduced emissions of Particulate and of NOx**, the production of which is proportional to the combustion temperature.

This electronically controlled CNH engine features **Multiple Work Modes**. The operator can select one of the following electronically pre-set power modes, depending on the type of job in hand:

**Maximum power:** 128 kW/172 hp, for very tough conditions

**Standard power:** 116 kW/156 hp, for normal loading conditions

**Economy power:** 99 kW/133 hp, for light load and carry applications.



An **Automatic power mode** can be also selected to automatically match the engine power curve, between maximum power and standard power, to the machine application.

A new, durable, efficient, comfortable and economic engine which contributes to reduced operating costs and increased profits.

# OF DURABILITY & EFFICIENCY



## INTEGRATED HYDRAULIC AND STEERING SYSTEM

The W130B hydraulic system consists of a new variable displacement, axial pistons pump **Load Sensing** regulated. The pump delivers 171 l/min at a maximum pressure of 250 bars.

Steering is soft, prompt and easy thanks to a **demand valve** which prioritises the diversion of the necessary flow to the steering cylinders. If steering is not required, all the hydraulic oil, is available for the front loader to deliver fast, efficient and productive cycles.

A small gear pump driven by an electric motor, which automatically switches on in case of engine shutoff, provides **emergency steering**, for operator safety and comfort.

The **closed centre** piloted control valve allows simultaneous movement under every load and engine speed condition.

In addition, controls are power assisted, with electromagnetic detent and the loader section of the control valve includes floating function.

Hydraulic and Steering: an integrated system which features operator comfort as well as top class safety, controllability and efficiency.



# W130B THE POWER

## THE EXCLUSIVE NEW HOLLAND COOLING MODULE

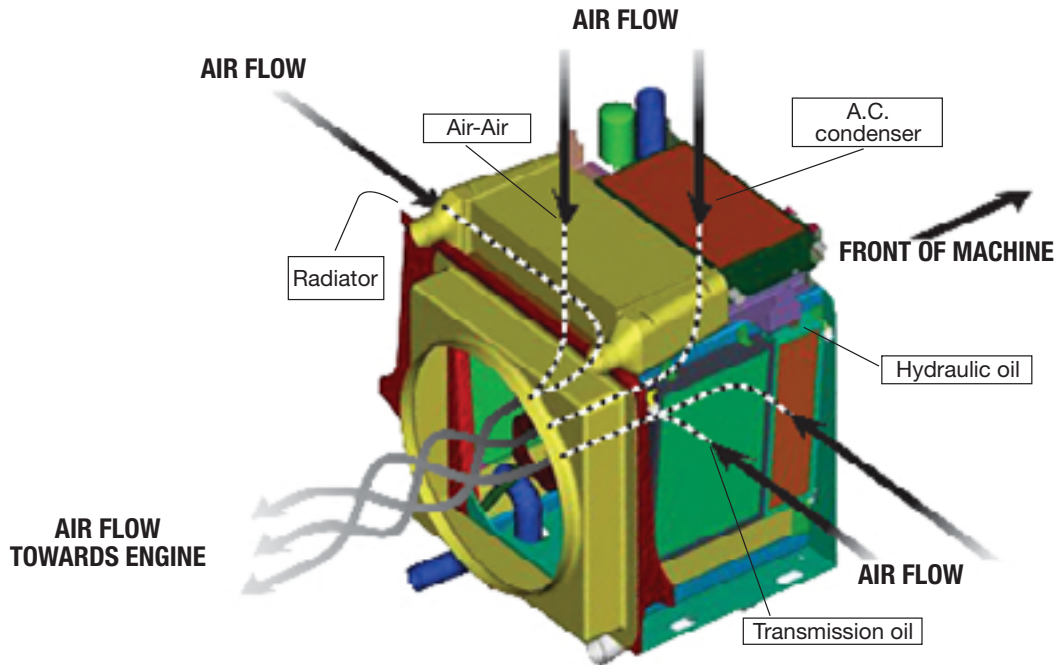

### **T** A.C.S. (Advanced Cooling System)

**The exclusive New Holland Cooling Module**

This exclusive Cooling Module looks like a cube positioned in the centre of the machine. All radiators are located around three sides of the cube to optimise both space and cooling effect. The coolant radiator is on the left-hand side while the hydraulic oil and transmission oil radiators are positioned in parallel on the opposite side. The engine after-cooler radiator and the air conditioner condenser are on top of the cube, also fitted in parallel.

To optimise the cooling effect of a fresh and clean air flow, the hydraulic oil tank is located inside the cube and can be easily reached thanks to the hinged liftable condenser of the airconditioning system. The position of the hydraulic tank, high above the pumps, avoids the risk of damage, increasing pumps durability.

A variable speed hydrostatic fan, automatically actuated by a thermostatic sensor, with eight plastic blades, draws fresh and clean air from outside through the radiators and the hydraulic oil tank.

A switch in the cab allows the operator to select the fan counter rotation for easy and automatic radiators cleaning.

**A real comfortable, durable, and efficient improvement offered by New Holland.**



# OF NOVELTY



## **T** BETTER BALANCE

The use of the compact and centrally mounted **Cooling Module** results in a wider free space in the back of the rear frame.

This innovative solution has allowed the New Holland engineers to reposition the engine and its components all the way back on the rear frame. Consequently, the centre of gravity is also moved backwards in a more convenient position to better counterbalance the loading effect.

A modern engine hood, which enhances rear visibility, has also been added.

Optimum stability and better rear visibility means greater operator safety and confidence, shorter cycle time, higher productivity: all which adds up to higher profitability.

# W130B THE POWER

## SPACE LAB CAB

The New Holland W130B is now equipped with a completely new designed and advanced cab featuring outstanding internal and external improvements.



“Space” means that:

- Access to the cab has been improved thanks to the **580mm** wide door (80 mm wider), which can be locked back at 180 deg., and to the new, wider stair with larger anti-slip steps.
- Internal volume has been **increased by 13%** and the glass area enhanced to provide perfect bucket and 360 deg. visibility.
- The steering column is tiltable and includes a high-tech dashboard, enabling easy functional checks from every position.
- The new contoured and suspended seat, adjustable in all directions, incorporates a retractable seat belt and adjustable armrests.

It can be supplied with optional head rest to let the operator work with maximum comfort in an extremely low noise atmosphere.



# OF SAFETY & COMFORT



“Lab” means an advanced laboratory where

- Vital information on the main components is provided by the new on-board computer and displayed on the new multi-language, high-tech digital LCD screen located on the dashboard just in front of the operator for easy reading;
- The "car standard" cab features an integrated **ROPS and FOPS structure** with tinted safety glass.
- Standard pressurisation, optional climatisation and FM radio, low noise level and modern and elegant interiors provides the operator with pleasant and comfortable working conditions, regardless of the external weather conditions.



**A machine cab several steps ahead of the rest in terms of state-of-the-art technology. A cab designed to provide maximum operator comfort and safety, allowing him to fully concentrate on the job in hand for better performance and higher productivity.**

# W130B THE POWER

## MAINTENANCE AND SERVICE



**T**he W130B is designed for simple and easy maintenance and service procedures thanks to its excellent ground level access to all the most important components and to the new high-tech digital display located on the dashboard, which keeps the operator fully aware of all machine main functions, such as engine and transmission diagnostics, error reporting and warning prompts.

Wide side panels, that open and close with a seagull wing movement, are light to lift and automatically self-locking in a safety position thanks to compressed air cylinders.

# OF ECONOMY

They give immediate access to most of the engine components, including the high pressure injection pump, alternator, fuel/water separator, engine oil filter, fuel filter, air filter and the engine electronic control panel.

Access to the hydraulic tank is provided by a third liftable panel, which is located on the top of the engine hood, behind the cab.

Grouped together in a protected and easily-accessible remote position on the rear left side of the machine are the engine oil, coolant and hydraulic oil valves, allowing easy and ecological discharge of fluids. All this adds up to maximum comfort, safety, efficiency and economy in the day-to-day use of the New Holland W130B.



# W130B SPECIFICATIONS



## ENGINE TIER 3A

Maximum power at 1800 rpm (ISO 14396/ECE R 120-SAE J 1995) 128 kW/172 hp  
 Net flywheel power at 1800 rpm (SAE J1349)..... 121 kW/162 hp  
 Rated engine speed .....2000 rpm  
 Maximum rated power (SAE J1995) ..... 121 kW/162 hp  
 Make and model.....CNH 667TA/EDB  
 Type.....Diesel, Common rail, turbo, aftercooler, electronic injection  
 Total displacement .....6.7 l  
 N° of cylinders .....6  
 Bore x stroke .....104 x 132 mm  
 Maximum torque at 1600 rpm.....73.0 daNm  
 Lubrication with gear pump

The engine conforms to European requirements for "low exhaust emission" in accordance with directive 97/68/EC TIER 3A.



## ENGINE MULTIPLE WORK MODES

The latest generation CNH TIER 3A common rail engine, electronically controlled, features **multiple work modes**. According to the type of application, the operator can select the following engine power modes:

- **Maximum power** ..... 128 kW/172 hp, for very tough conditions
- **Standard power** ..... 116 kW/156 hp, for normal loading conditions
- **Economy power** ...99 kW/133 hp, for light load & carry applications
- **Automatic power mode**: to automatically match the power curve to the application.

Perfect electronic control to get the best performances in every type of job while contributing to reduced fuel consumption.



## ELECTRICAL SYSTEM

Voltage .....24 V  
 Batteries, in series .....2  
 - Capacity ..... 155 Ah  
 - Type .....maintenance-free  
 Starter motor .....7.8 kW  
 Alternator capacity .....65 A



## TORQUE CONVERTER

Type .....single stage / single phase  
 Torque multiplication ratio .....2.66 : 1



## TRANSMISSION

Type: PowerShift countershaft design with four forward and three reverse speeds

Control: single lever electric "fingertip" type.

Forward speeds.....km/h  
 1° .....6.9  
 2° .....13.5  
 3° .....23.9  
 4° .....38.6  
 Reverse speeds  
 1° .....7.3  
 2° .....14.2  
 3° .....25.0

with 20.5-25 L3 tyres

Safety device prevents engine starting in gear

**Electronic Transmission System (ETS)**: allows the operator to dedicate attention to the work cycle.

The on-board computer automatically finds the right gear in relation to the type of work.

**"HOLD"** function to maintain selected speed with the machine operating on a slope.

**"KICK-DOWN"** function to shift from 2nd to 1st gear when high pushability is required.

**"DOWNSHIFT"** function to select the most suitable speed with the machine on a slope. Low gears favour the use of the engine brake function and consequently reduce brake use.

Forward and reverse control switch.



## AXLES

Rigid front axle, oscillating rear axle designed for heavy duty applications

Rear axle oscillation.....24°

Rear wheel vertical travel .....505 mm

"Limited slip" differentials supplied standard.

Hermetically sealed final drives and wet disc brakes



## BRAKES

**Service brakes**.....self-adjusting

Type .....wet disc brakes on all four wheels

Servo-assisted hydraulic brake circuit.

Independent circuit for each axle.

Control pedal located to left of steering column.

Electrical transmission disengagement switch.

The brake circuit complies with the following international standards:

ISO 3450, CEE 71/320, SAE J1473

**Parking brake**: spring applied hydraulically released caliper disc brake on transmission output shaft.

Electrical control by means of switch in cab.



## TYRES

Type .....tubeless

Radial .....20.5-25 RT-3B

20.5-25 RM-94A

20.5-25 XHA

20.5-25 GP-2B

20.5-25 RL-5K

20.5-25 XLD-D2

550/65-25GP-3D



## HYDRAULIC SYSTEM

Type .....load sensing circuit, closed centre

Pump.....variable displacement -axial pistons

feeding the integrated implement and steering system

Max. flow delivery.....171 l/min

Max. working pressure .....250 bar

Control valve .....2 spool

3 spool

Control .....piloted dual lever  
 piloted, single lever

Double-acting hydraulic cylinders  
 Booms .....2  
 Bore x stroke .....121 x 788 mm  
 Bucket.....1  
 Bore x stroke .....127 x 620 mm  
 Operating time  
 Lift .....6.3 s  
 Lower empty.....4.7 s  
 Dump .....1.3 s  
 Hydraulic lines and connecting flanges are equipped with O-ring seals.

**L.T.S. device**

Load Travel Stabiliser. Invaluable for loading and transport on uneven terrain.



**STEERING**

Type.....**Orbitrol**, hydraulically actuated with priority valve  
 Pump .....utilises the hydraulic system pump  
 Max. flow rate .....100 l/min  
 Max. working pressure .....241 bar  
 Cylinders .....2, double acting  
 Bore x stroke .....76 x 482 mm  
 Emergency steering circuit with electric motor activated by the onboard computer.



**CAB**

ROPS/FOPS modular cab.  
 Excellent, all-round, visibility. The ROPS/FOPS cab complies with the following standards:  
 ROPS - EN 13510  
 FOPS - EN ISO 3449



**CAPACITIES**

	Litres
Lube oil .....	15
Coolant .....	36
Fuel tank .....	246
Transmission oil .....	19
Hydraulic system .....	148
Axles F/R.....	22/22

**DIMENSIONS mm**

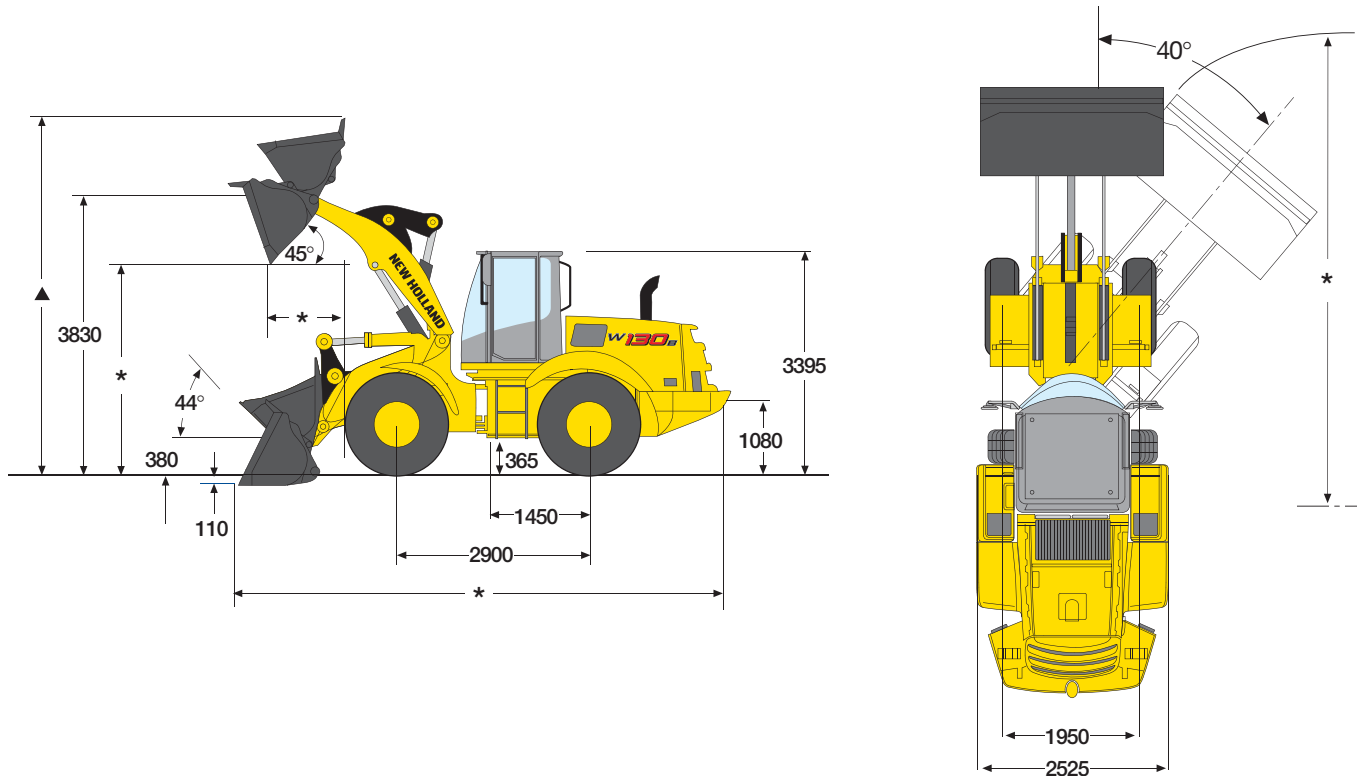

# W130B

## PERFORMANCES

### GENERAL PURPOSE

BUCKET TYPE		WITH TEETH AND SEGMENTS		WITH CUTTING EDGE EXTENSION		WITH TEETH		WITH Q.C.**	
								TEETH+SEG.	CUTTING EDGE
Bucket capacity	<b>m<sup>3</sup></b>	2.2	2.4	2.2	2.4	2.1	2.3	2.0	2.1
Bucket weight	<b>kg</b>	870	915	840	885	860	905	1120	1090
Bucket width	<b>mm</b>	2600	2600	2600	2600	2600	2600	2600	2600
Max height with boom raised ▲	<b>mm</b>	4955	5030	4955	5030	4955	5030	5100	4980
Dump height at 45° *	<b>mm</b>	2750	2800	2845	2800	2750	2800	2685	2600
Reach at 45° *	<b>mm</b>	1070	1015	970	1015	1070	1015	1115	1030
Overall length (bucket on ground)*	<b>mm</b>	7465	7385	7340	7385	7465	7385	7555	7560
Turning radius* (bucket at carry position)	<b>m</b>	5.8	5.8	5.7	5.8	5.7	5.8	5.7	5.7
Breakout force	<b>daN</b>	11230	10515	11260	10545	11310	10595	10060	10090
Static tipping load 0°	<b>kg</b>	10440	10330	10480	10340	10560	10450	9605	9665
40°	<b>kg</b>	9090	8990	9130	9000	9210	9110	8315	8375
Max operating weight	<b>kg</b>	12490	12535	12460	12505	12480	12500	12940	12895

\* At bucket cutting edge

\*\* With Quick Coupler

## PERFORMANCE "LONG BOOM"

### GENERAL PURPOSE

BUCKET TYPE		WITH CUTTING EDGE EXTENSION
Bucket capacity	<b>m<sup>3</sup></b>	2.1
Bucket weight	<b>kg</b>	840
Bucket width	<b>mm</b>	2600
Dump height at 45°	<b>mm</b>	3260
Reach at 45° (at 2130 mm height)	<b>mm</b>	1850
Overall length (bucket on ground)	<b>mm</b>	7725
Overall height (bucket raised)	<b>mm</b>	5370
Turning radius (at bucket edge)	<b>m</b>	5.94
Breakout force	<b>kg</b>	11595
Static tipping load: 0°	<b>kg</b>	8590
40°	<b>kg</b>	7450
Operating weight	<b>kg</b>	12550



Note: All performance data and specifications based on a unit with 20.5-25 XTLA Radial tyres, ROPS cab and heavy counterweight. All data is obtained in compliance with the latest applicable SAE Recommended Practices including J732c, J742b and ISO 6746/1, ISO 6746/2 and ISO 8313.

# W130BTC

WITH QUICK COUPLER

## WITH BUCKET - DIMENSIONS mm

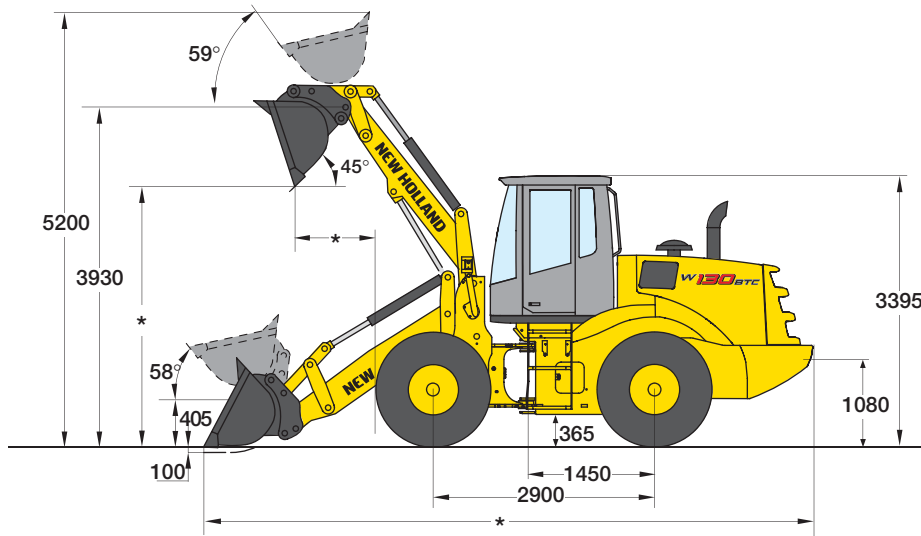

## PERFORMANCES

### GENERAL PURPOSE

BUCKET TYPE		WITHOUT TEETH	WITH TEETH	WITH CUTTING EDGE	WITH TEETH AND SEGMENTS
Bucket capacity	m <sup>3</sup>	2.0	2.0	2.1	2.1
Bucket weight (including Quick Coupler)	kg	1085	1125	1415	1425
Bucket width (maximum)	mm	2600	2600	2600	2600
Dump height at 45° *	mm	2620	2525	2540	2525
Reach at 45° *	mm	1170	1260	1115	1150
Overall length (bucket on ground) *	mm	7685	7830	7800	7830
Turning radius (bucket at carry position)	m	5.7	5.7	5.7	5.7
Breakout force	daN	12810	11935	12135	11935
Static tipping load:					
0°	kg	9010	9070	8930	8890
40°	kg	7795	7855	7720	7685
Max operating weight	kg	12865	12910	13020	13055

\* At bucket cutting edge

## WITH PALLET FORK - DIMENSIONS mm

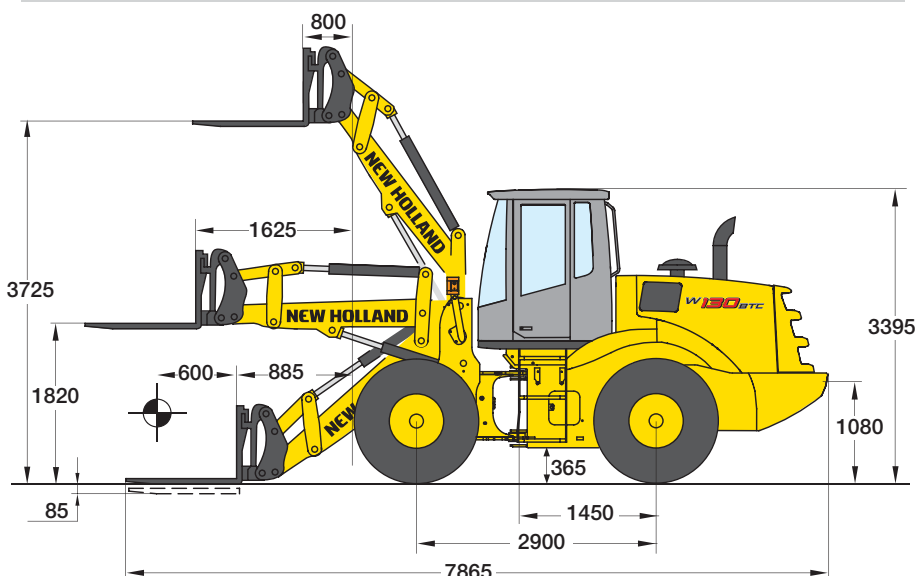

## PERFORMANCES

PALLET FORK		
Fork length	mm	1220
Fork weight (including Quick Coupler)	kg	730
Ground to top of tine clearance	mm	3725
Reach with arms horizontal	mm	1625
Overall length (tines on ground)	mm	7865
Operating load		
- rough terrain	kg	3420
- firm and level ground	kg	4560
Static tipping load (level arms, level fork, 600 mm load center):		
0°	kg	6550
40°	kg	5700
Operating weight	kg	12150

Note: All performance data and specifications based on a unit with 20.5-25 XTLA Radial tyres and ROPS cab. All data is obtained in compliance with the latest applicable SAE Recommended Practices including J732c, J742b and ISO 6746/1, ISO 6746/2 and ISO 8313.

# STANDARD EQUIPMENT

- 70 A alternator voltage regulator
- A.C.S., Advanced Cooling Module centrally mounted with integrated hydraulic oil tank for:
  - transmission oil
  - engine coolant
  - hydraulic oil
  - air to air aftercooler
  - air conditioner condenser (if equipped)
- Antifreeze
- Automatic return-to-dig
- Bucket and lift levers with hydraulic power assist and electromagnetic detent
- Bucket position indicator
- Centrally located fuse box
- Electrical disconnect
- Emergency steering
- Four-wheel drive
- Front and rear halogen flood lights
- Full flow hydraulic system with 10 micron filter
- Horn
- Hydraulic driven fan
- Hydraulic wet disc brakes
- Instrumental Cluster:
  - Analog Gauges:**
    - Transmission Temperature
    - Engine Coolant Temperature
    - Hydraulic Oil Temperature
    - Fuel Level
  - Audible and Visual alarms:**
    - Cautionary and critical Levels
    - Directional/Brights Indication

- Low Fuel
- Directional Signals
- Low Oil Pressure
- LCD Screen:**
  - Hour Meter
  - Time
  - F/N/R Indication
  - Trip computer
  - Metric/English
  - Warning Prompts
  - Engine Speed
  - Automatic Trans Indication
  - DeClutch Indication
  - Fuel Consumption
  - Engine Diagnostic
  - Error Reporting
  - Travel Speed
  - Current Gear Selection
  - Engine Mode Indication
  - Multiple Languages
  - Transmission Diagnostics
- Limited slip differentials axles
- Planetary axles
- Power steering
- Remote drain points
- Retractable seat belt
- ROPS/FOPS Cab
- Single lever electrically actuated proportional Powershift transmission
- Side covers
- Spring applied hydraulic releases disc parking brake
- Suspended and adjustable cloth seat
- Tail lights and stop lights combined
- Tilt steering column
- Tubeless tires
- Two-element dry-type air cleaner
- Two batteries of 155 Ah each

# OPTIONS

- 2 spool valve with joystick
- 3 spool valve with 3 levers
- 3 spool valve with joystick and 1 lever
- Air suspended and fully adjustable cloth seat
- Automatic Airconditioner
- Buckets selection with teeth and cutting edge
- Cold weather package
- Fire extinguisher
- Full view air precleaner
- Head rest
- Italian homologation
- LTS Load Travel Stabiliser
- Quick Coupler
- Radio
- Rotating beacon
- Transmission guard
- Transfer fuel pump kit
- Tool box
- TUV homologation
- Wide choice of tyres
- Wide fenders with LH and RH steps

Note: standard and optional equipment may vary by country. Consult your NEW HOLLAND dealer for specific details.

AT YOUR OWN DEALERSHIP

The information contained in this brochure is intended to be a general nature only. The NEW HOLLAND KOBELCO CONSTRUCTION MACHINERY S.p.A. company may at any time and from time to time, for technical or other necessary reasons, modify any of the details or specifications of the product described in this brochure. Illustrations do not necessarily show products in standard conditions. The dimensions, weights and capacities shown herein, as well as any conversion data used, are approximate only and are subject to variations within normal manufacturing techniques.

Published by NEW HOLLAND KOBELCO CONSTRUCTION MACHINERY S.p.A.  
Printed in Italy - LEADER Firenze - Cod. 73301 443GB - Printed 07/08

Printed on recycled paper  
CoC-FSC 000010 CQ Mixed sources



ELEMENTAL  
CHLORINE  
FREE  
GUARANTEED



BUILT AROUND YOU

www.newholland.com