



# NEW HOLLAND

## F200



NET FLYWHEEL POWER

149 kW - 200 hp

OPERATING WEIGHT

17 250 kg



**NEW HOLLAND**

CONSTRUCTION

**BUILT AROUND YOU**

# F200 SPECIFICATIONS



## OPERATING WEIGHT

Unit with coolant, hydraulic, full fuel tank, operator and ROPS cab  
 On front wheels .....5103 kg  
 On rear wheels .....12147 kg  
 Total.....17250 kg



## ENGINE TIER 2

Choice of two engines:  
 - Tier 2 - Emissioned  
 - Not emissioned  
 Net flywheel power (SAE J1349) .....149 kW/200 hp  
 Both engines deliver the same net flywheel power  
 at the rated engine speed.....2200 rpm  
 Stated net flywheel power is delivered up to 2500 m a.s.l.

Make and model.....(Emissioned) Cummins 6 CTAA 8.3 Tier 2  
 (Not emissioned) Cummins 6 CT 8.3  
 Type .....Diesel, 4 stroke, direct injection turbocharged  
 Total displacement .....8.3 l  
 N° of cylinders .....6  
 Bore x stroke .....114 x 135 mm  
 Maximum torque:  
 emissioned - 1600 rpm.....87 daNm  
 not emissioned - 1300 rpm.....77 daNm



## ELECTRICAL SYSTEM

Voltage .....24 V  
 Batteries in series .....2  
 Total capacity .....100 Ah  
 Alternator capacity .....70 A



## TRANSMISSION

Type: direct drive PowerShift, modulated shift on-the-go with inching pedal. Eight speed forward and four reverse.  
 Control: electric, single lever “bump type”

Speeds	Forward	Reverse
	km/h	km/h
1	3.9	3.9
2	5.5	7.6
3	7.6	15.5
4	10.6	30.6
5	15.5	-
6	21.7	-
7	30.6	-
8	43.0	-



## TANDEM DRIVE HOUSING

Welded box section, wall thickness .....16 mm  
 Chain pitch .....31.8 mm  
 Interchangeable axles and sprockets, mounted on ball bearings.  
 Tandem oscillation, each way .....20°



## AXLE FRONT

High clearance, high strength welded steel construction with 19° oscillation each way.  
 Wheel lean 18° right and left, hydraulically operated.  
 Ground clearance .....622 mm



## AXLE REAR

Heavy duty cast iron housing. Heat treated steel axles with tapered roller bearings.  
 Ground clearance .....380 mm  
 Super max-trac (limited slip) differential.



## BRAKE SYSTEM

- **Service brakes:** Foot operated, hydraulically actuated, multiple sealed inboard wet-disc brakes located at the four tandem hubs.
- **Emergency brakes:** Each service system circuit is equipped with a nitrogen accumulator, ensuring brake efficiency with the engine off and operator warning system (visual and audible).
- **Parking brake:** Hand operated, caliper installed on transmission output shaft.



## FRAMES

- Front frame  
 Welded box .....298 x 254 mm  
 Frame section weight .....173 kg/m
- Rear frame  
 Welded box .....299 x 121 mm  
 Frame section weight each side .....114 kg/m



## DRAWBAR

Type “A” frame welded construction with centre mounted circle turn motor.  
 Connections: shim-adjustable ball and socket.



## CIRCLE

Outside diameter .....1753 mm  
 Fabricated “T” section .....178 x 168 x 38 mm  
 Degrees turn .....360°  
 Wear surface, replaceable phenolic inserts.  
 Total wear plate area .....2845 cm<sup>2</sup>  
 Circle turn gears enclosed and running in oil.

# F200

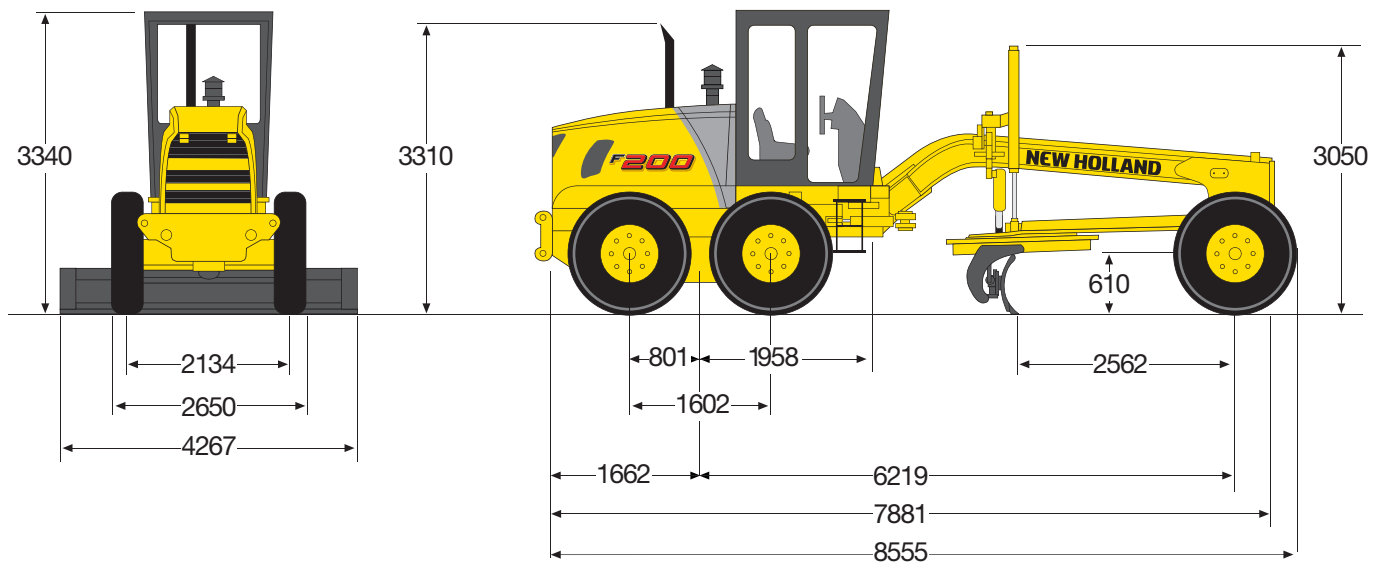

## BLADE

One piece "Roll-Away", involute curve blade with replaceable end bits and cutting edges.

Hydraulic blade side shift and pitch.

Available sizes .....4267 x 671 x 22 mm  
 .....3962 x 671 x 22 mm  
 .....3658 x 622 x 22 mm

Lift above ground .....445 mm

Blade side shift left .....533 mm

Blade side shift right .....686 mm

Blade penetration .....712 mm

Reach outside wheels (STD blade, frame in stright position)\*

- left .....1978 mm

- right .....2174 mm

Blade pitch range.....backward 5°

forward 40°

Bank cutting angle (left and right) .....90°

Blade pressure

- with ROPS cab.....9135 kg

- with ROPS cab, ripper and front blade .....10885 kg

\* (with frame art. 25° + 684 mm L&R)



## HYDRAULIC SYSTEM

Full hydraulic "Load Sensing" system with variable displacement piston pump, pressure and flow compensated control valve.

Blade lifting cylinder mounted on rotating saddle. Saddle locking controlled by 1 electro-hydraulic pin actuated from the dashboard.

- max flow delivery .....186 l/min

- max working pressure .....179 bar



## STEERING

- Front wheels

Type .....hydrostatic, orbitrol

Pump .....gear type

Capacity at 2200 rpm .....43 l/min

Cylinders .....2

bore x stroke .....64 x 267 mm

Wheel steer angle (left & right) .....48°

- Articulated frame

Hydraulic actuated articulation (left & right) .....25°

Cylinders .....2

bore x stroke .....80 x 377 mm

Minimum turning radius .....7.3 m



## TYRES

One set of the following heavy-duty tyres as listed below:

14.00 x 24 (10PR)

14.00 x 24 (12PR)

16.00 x 24 (12PR)

17.50 x 25 (12PR)

20.50 x 25 (12PR)



## CAPACITIES

Engine ..... litres

Fuel tank .....341.0

Cooling system.....40.0

Crankcase .....19.0

Transmission .....22.0

Tandem case each .....23.0

Hydraulic tank .....95.6

Rear axle .....25.0

Circle turn housing.....3.0

# ATTACHMENTS

## FRONT SCARIFIER

Type .....	parallelogram, front mounted
Weight (5 teeth) .....	570 kg
Width .....	1168 mm
Number of teeth .....	5 (std.) or 11 (opt.)
Width between teeth:	
- with 5 teeth .....	229 mm
- with 11 teeth .....	114 mm
Lift above ground .....	527 mm
Penetration .....	318 mm
Machine length with front scarifier .....	9400 mm

## REAR RIPPER

Type .....	parallelogram, rear mounted
Weight .....	985 kg

Width .....	2340 mm
Number of teeth .....	5
Width between teeth .....	530 mm
Lift above ground .....	518 mm
Penetration .....	437 mm
Machine length with ripper/scarifier .....	9735 mm

## DOZER BLADE

Type .....	front mounted
Weight .....	1165 kg
Dimensions .....	2762 x 953 mm
Lift above ground .....	622 mm
Penetration .....	165 mm
Machine length with dozer blade .....	9525 mm

# STANDARD EQUIPMENT

- Adjustable operator's console
- Adjustable tilt steering wheel
- Air cleaner, automatic dust ejector
- Alternator - 70 Amp
- Antifreeze
- Back-up alarm
- Blade 4267 mm
- Blade side shift & pitch, hydraulic
- Controls, hydraulic: Articulation, Blade lift/lower, Blade side shift, Circle side shift, Circle turn, Front & rear attachment, Saddle lock, Wheel lean
- Electronic data monitor
- Engine side panels

- Engine TIER 1 or TIER 2 emission regulation
- Fan, with finger guard
- Gauges: Engine coolant temperature, Engine oil pressure, Fuel level, Transmission oil pressure, Transmission oil temperature
- Horn
- Light package: Moldboard work lights (2), Rear work light (2), Turn signals, stop, taillights & warning flashers
- Muffler
- Rear drawbar
- ROPS canopy with inside rear view mirror
- Saddle 5 points
- Tyres 17.50 x 25 (12PR)

# OPTIONAL

- Additional hydraulic functions
- Air conditioning
- Blade 3962 mm
- Blade 3658 mm
- Blade extension, 600 mm each side
- Blade floatation control
- Blade rock bits
- Cab mounted flood lights (2)
- Cold weather starting aid
- Dozer blade floatation control
- Emergency steering
- Front counterweight
- Front pull hook
- Front push plate
- Outside rear view mirrors
- Piping for front attachment
- Piping for rear attachment

- Pressurised cab
- Rear axle with differential lock-unlock and wet disc brakes at the four tandems hubs.
- ROPS cab with: Dome light, Floor mat, Front/rear wipers 2 speed and windows washer, Heater, Inside rear view mirror, Sound suppression, Suspension seat, Seat belt, Tinted safety glass
- Rotation beacon/strobe light
- Saddle fixed
- Saddle 3 points
- Slow moving emblem
- Spare tyre
- Tyre 14.00 x 24 (10PR), 14.00 x 24 (12PR), 16.00 x 24 (12PR), 20.50 x 25 (12PR)
- Tyre inflation
- Tool box
- Tool kit
- Vandalism protection
- Warning beacon

Note: standard and optional equipment may vary by country. Consult your NEW HOLLAND dealer for specific details.

### AT YOUR OWN DEALERSHIP

The information contained in this brochure is intended to be a general nature only. The NEW HOLLAND KOBELCO CONSTRUCTION MACHINERY S.p.A. company may at any time and from time to time, for technical or other necessary reasons, modify any of the details or specifications of the product described in this brochure. Illustrations do not necessarily show products in standard conditions. The dimensions, weights and capacities shown herein, as well as any conversion data used, are approximate only and are subject to variations within normal manufacturing techniques.

Published by NEW HOLLAND KOBELCO CONSTRUCTION MACHINERY S.p.A  
Printed in Italy - LEADER Firenze - Cod. 73301 263GB - Printed 05/08

Printed on recycled paper  
CoC-FSC 000010 CQ Mixed sources



ELEMENTAL  
CHLORINE  
FREE  
GUARANTEED

FIAT  
GROUP



BUILT AROUND YOU

www.newholland.com